

Now the turbine meter is smart

Turbine Meter RQ UST1 with Universal Smart Transmitter and HART® Communication

Sensors



Designed for the process:

- direct measurement of volume and volumetric flow rate
- measurement of low viscosities
- high accuracy
- 2-wire technique
- status message for preventive maintenance

Measuring principle

The turbine meter is an indirect volumetric meter. Its main component is an axial turbine wheel turning freely in the flowing liquid. The turbine wheel is set in rotation by the fluid at a speed which is directly proportional to the average velocity of the fluid in the free cross-section of the turbine meter. The speed of the turbine wheel is therefore directly proportional to the volumetric rate of flow, with the number of revolutions proportional to the volume that has passed through the meter.

The rotation will be transmitted through the housing wall by means of a non-interacting magnetic-inductive sensor to the electronic converter UST1. From there a flow-proportional 4-20 mA signal, in addition to the integral display (with e.g. actual flow rate, total volume or resettable totalizer), is available.

Major applications are process control or flow control loops in any branch of industry.



Technical data

Measured error (accuracy)	<± 0,3% under reference conditions (depending on flow range and liquid)
Repeatability	0.03 % of measured value
Operating temperature	-40°C to +80°C (-196°C to +250°C upon request)
Ambient temperature	-10°C to +70°C
Viscosity range	0.2 to 50 mPa.s
Process connection	Flanges for ratings PN 6 to 320 (DIN 2501) or Class 150 to 2500 (ANSI B 16.5)
Electrical connection	Sensor supply 14 to 30 VDC 2-wire technique, 4-20 mA, HART® or current pulses (without HART®)
Material	Wetted parts: stainless 1.4571/1.4429, other materials upon request Electronics housing: cast aluminum
Degree of protection	IP 67
Safety class	EEx ia IIC T4, EEx d in preparation, approvals in accordance with CSA and FM in preparation
EU declaration of conformity	In accordance with EMC directives 89/336/EWG, 92/3/EWG, 93/68 EWG, EN 50081-1, EN 50082-2 and NAMUR NE 21

Measuring ranges

RQ		
Nominal size (mm)	Nominal size (inch)	Nominal flow or full-scale value (m³/h)
10	-	1.5
15	½	6
20	¾	12
25	1	18
32	1 ¼	30
40	1 ½	42
50	2	72
65	2 ½	120
80	3	180
100	4	300
150	6	600
200	8	1200
250	10	1800
300	12	2400

Advantages of the Turbine Meter RQ with UST1

... based on the proven turbine meter principle

- Direct measurement of volume and flow rate
- Long meter life and reliability
- Measurement of low viscosities (even LPG)
- Measurement of non-conductive liquids possible (especially hydrocarbons)
- Highest accuracy/repeatability
- Minimized influence of flow profile and viscosity due to optimized design
- No zero drift
- Low pressure loss (max. 0.4 bar at nominal flow)

Main dimensions

Type	RQ 10	RQ 15	RQ 20	RQ 25	RQ 32	RQ 40	RQ 50	RQ 65
L	140	140	150	150	160	170	170	190
H	255	265	265	270	270	280	280	290
∅ D	90	95	105	115	140	150	165	185

Typ	RQ 80	RQ 100	RQ 150	RQ 200	RQ 250	RQ 300
L	200	200	300	400	500	600
H	300	310	330	360	385	410
∅ D	200	235	300	375	450	515

Dimensions in mm (PN40 / Class 300)

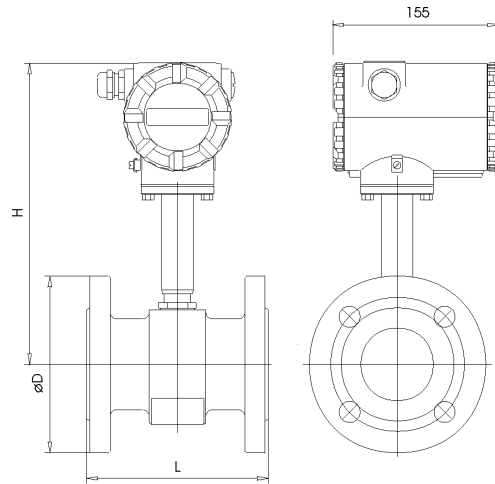

... combined with modern electronics suitable for communication

- High-resolution sensor without moving parts
- 2-wire technology
- 4-20 mA output or pulse output
- Local display
- Special, easy-to-use software (SensorPort) and easy-to-handle hardware
- HART protocol (Profibus PA in preparation)
- Hand-held terminal available
- Status messages allow preventive maintenance

Connection diagram

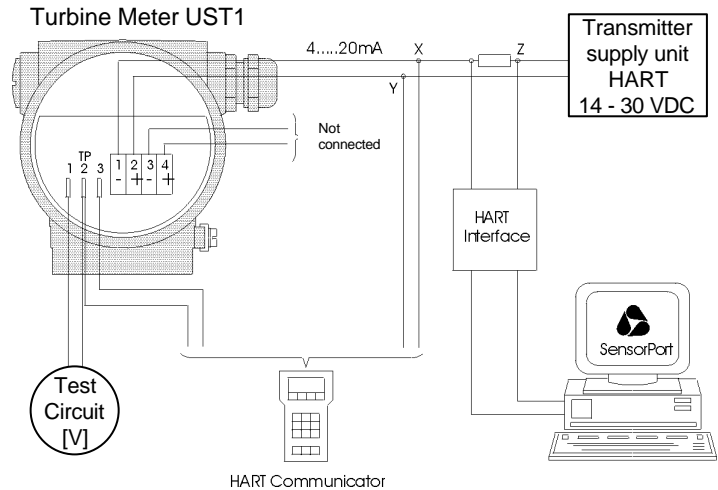

Subject to changes without notice